



The Original Expansion  
Bolt for Structural Steel



Now CE marked



by **lindapter**<sup>®</sup>



**THE ORIGINAL EXPANSION BOLT FOR STRUCTURAL STEEL**

Lindapter®, the steelwork connection specialists, invented the Hollo-Bolt® as a fast, cost effective connection for Structural Hollow Section (SHS). The 'blind connection' technique requires installation access to only one side of the steel section for exceptional convenience. In comparison to alternative methods such as welding, a Hollo-Bolt connection can be quickly installed by simply inserting the fastener into pre-drilled holes and tightening with a torque wrench.

Since the Hollo-Bolt was first launched in 1995, the product range has been continuously developed to meet the diverse requirements of Structural Engineers and Architects, with enhancements including new head types, lengths, finishes and performance improvements.



**10 REASONS TO USE HOLLO-BOLT**

- 1**

Fast, time saving installation
- 2**

Lower labour costs
- 3**

Easy to install from just one side
- 4**

For SHS and other hollow sections
- 5**

No need to weld, no hot work permits
- 6**

High resistance to shear and tension
- 7**

Hollo-Bolt (HCF) for 3x Clamping Force
- 8**

Various corrosion resistant options
- 9**

Aesthetically pleasing connections
- 10**

Independently approved product performance

**INTERNATIONAL RECOGNITION**

The British Constructional Steelwork Association (BCSA) and Steel Construction Institute (SCI) include the Hollo-Bolt as a structural connection in the design guide 'Joints in Steel Construction'<sup>(a)</sup>. For more information, please see pages 22 & 23.

The American Institute of Steel Construction (AISC) also recognises the Hollo-Bolt in the Steel Construction Manual<sup>(b)</sup>.

Engineers and Architects around the world specify the Hollo-Bolt as a time and labour saving method of connecting structural steel frames or securing almost anything to SHS (see page 8-19 for project examples).

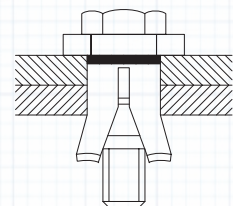

[www.hollo-bolt.com](http://www.hollo-bolt.com)

**Drawing from Joints in Steel Construction: Simple Joints to Eurocode 3'**  
 Cover (a) & drawing Copyright © BCSA / SCI. Cover (b) Copyright © AISC.  
 Reprinted with permission. All rights reserved.



**CONTENTS**

<b>Why use a Hollo-Bolt?.....</b>	<b>4</b>	<b>Installation Guidance.....</b>	<b>20</b>
<b>Hollo-Bolt Options.....</b>	<b>5</b>	<b>Design Data.....</b>	<b>22</b>
<b>Expansion Mechanism.....</b>	<b>6</b>	<b>FAQs.....</b>	<b>24</b>
<b>Clamping Force.....</b>	<b>7</b>	<b>Lindapter Service &amp; Products.....</b>	<b>26</b>
<b>Project Experience.....</b>	<b>8</b>		

**TYPICAL HOLLO-BOLT APPLICATIONS**

- Structural Frames
- Glazing and Roofs
- Staircases and Handrails
- Balconies and Canopies
- Façades and Cladding
- Towers and Masts

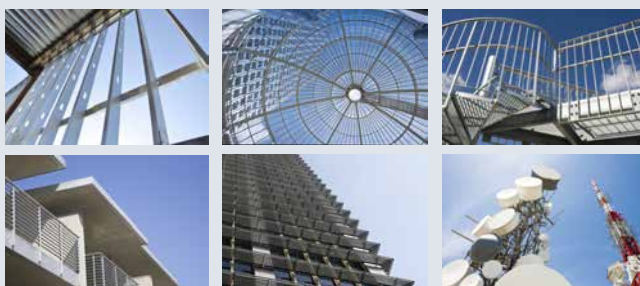

**APPROVALS**

**CE Marking** provides additional security for Engineers, Specifiers and Contractors by demonstrating Lindapter's commitment to quality manufacturing and transparency of product performance.



Lindapter's Factory Production Control System is independently evaluated to ensure only premium quality products leave the production line, whilst product performance is scrutinised under comprehensive testing programmes and published in European Technical Approvals (ETAs). In this brochure you will find the Eurocode 3 Characteristic Values (as published in the official ETA-10/0416) and also standard Safe Working Loads for resistance to tensile and shear loading. For more information on CE Marking, please refer to the website: [www.lindapter.com/about/ce](http://www.lindapter.com/about/ce)

**DIBt** - Deutsches Institut für Bautechnik is a respected organisation that approves construction products for use in Structural and Civil Engineering industries in Germany.



**TÜV** are the certifying authority for safety, quality and environmental protection in Germany. Hollo-Bolts are produced under strict quality and environment management systems to ensure consistently high manufacturing standards across the range.



**Disclaimer**

Lindapter International supplies components in good faith, on the assumption that customers fully understand the loadings, safety factors and physical parameters of the products involved. Customers or users who are unaware or unsure of any details should refer to Lindapter International before use. Responsibility for loss, damage or other consequences of misuse cannot be accepted. Lindapter makes every effort to ensure that technical specifications and other product descriptions are correct. 'Specification' shall mean the specification (relating to the use of the materials) set out in the quotation given by the Seller to the Buyer. Responsibility for errors or omissions cannot be accepted. All dimensions stated are subject to production tolerances - if in doubt please check with Lindapter.

**Applications**

All the applications featured in the brochure are based on real projects. For more information and further examples visit: [www.hollo-bolt.com](http://www.hollo-bolt.com)

**© Lindapter International 2013**

Lindapter, Hollo-Bolt and Lindibolt are registered trademarks. In the interests of improving the quality and performance of Lindapter products, we reserve the right to make specification changes without prior notice.



ALTERNATIVE CONNECTION METHODS

**WELDING**

- ✘ Hot work permit required
- ✘ Skilled labour needed
- ✘ Requires power/consumables

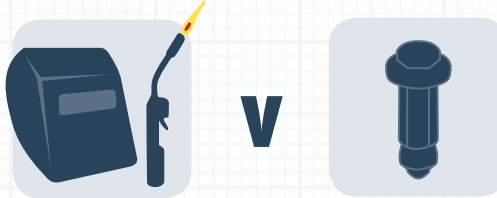

**HOLLO-BOLT**

- ✔ A safe and permanent connection that is quick to install using hand tools.

**THROUGH-BOLTING**

- ✘ Inappropriate for larger SHS
- ✘ Strength of connection not guaranteed
- ✘ Risk of SHS deformation



**HOLLO-BOLT**

- ✔ A reliable high strength fixing, supported by independently approved Safe Working Loads.

**BRACKETS & STRAPPING**

- ✘ Unsightly finish
- ✘ Time consuming installation
- ✘ Low capacity in friction



**HOLLO-BOLT**

- ✔ Architectural options include the Hollo-Bolt Flush Fit for a very discreet connection.

**CUTTING ACCESS HOLES**

- ✘ Expensive & time consuming
- ✘ Unsuitable for structural connections
- ✘ Defeats any architectural benefit of SHS



**HOLLO-BOLT**

- ✔ A neat, labour saving SHS connection, suitable for structural applications.

**SIMPLE HOLLO-BOLT INSTALLATION**

*Project Example: Salt River Fields Stadium, Arizona, USA*

1. Deliver pre-drilled steel to site.
2. Align the pre-drilled fixture and insert the Hollo-Bolt.
3. Using a torque wrench, tighten the Hollo-Bolt to the recommended torque.





**HEAD VARIANTS**

The Hollo-Bolt is available in three head types to complement diverse architectural designs. Lindapter also has the capability to produce customised Hollo-Bolts; a service passionately referred to as 'Engineered Solutions'.

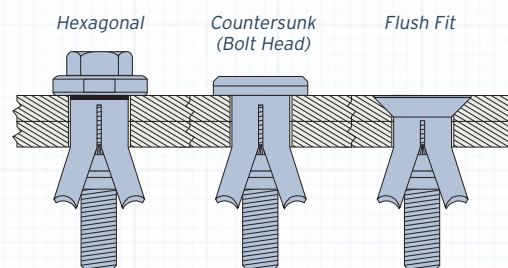

**HEXAGONAL**

**Visible protrusion:** Standard

**Description:** The Hollo-Bolt collar and head of the Grade 8.8 bolt are evident above the surface of the steel section. This head variant is the usual choice for the majority of SHS connections, or where architects favour an 'industrial' look.



**COUNTERSUNK (BOLT HEAD)**

**Visible protrusion:** Minimal

**Description:** This discreet midway option has a smaller protrusion for the perfect balance of appearance and convenience, and features a Grade 10.9 countersunk bolt with a special collar designed to accommodate the entire bolt head. Drilling countersunk holes in the steel section is not required.



**FLUSH FIT**

**Visible protrusion:** Zero

**Description:** The innovative Flush Fit Hollo-Bolt is entirely concealed within a drilled countersunk hole once installed, leaving no protrusion above the surface of the steel section - the perfect solution for architects!



**ENGINEERED SOLUTIONS**

**Visible protrusion:** Customised

**Description:** For the rare connection requirement that an off-the-shelf Hollo-Bolt cannot fulfil, Lindapter's Research and Development Facility has the capability to design and manufacture custom connection solutions. Just one example of a custom Hollo-Bolt is the tamperproof Button Security Head variant, developed for use in prisons.

**CORROSION RESISTANCE**

The Hollo-Bolt is available in a series of protective coatings and materials to provide a customisable yet off-the-shelf connection solution. See right for availability:

*\* Sheraplex is an advanced coating designed for intricately shaped and precision machined components. The two-stage treatment process first involves Sheradising (Zinc coating), then secondly applying an organic barrier layer. The resulting surface has a smooth matt grey finish that provides high corrosion resistance.*

	Hex Head	Countersunk	Flush Fit
Bright Zinc Plated & JS500	✓	✓	✓
Hot Dip Galvanised	✓		
Sheraplex*	✓	✓	✓
Stainless Steel (Grade 316)	✓	✓	✓
M8	✓	✓	✓
M10	✓	✓	✓
M12	✓	✓	✓
<b>HCF</b> M16	✓	✓	
<b>HCF</b> M20	✓		

➔ Sizes M16 and M20, known as the Hollo-Bolt (HCF), feature a patented **High Clamping Force** mechanism to produce three times more clamping force than the same sized product without the mechanism. The significance of clamping force and the superior performance of Lindapter's unique Hollo-Bolt (HCF) is illustrated on page 6.



**HOLLO-BOLT & HOLLO-BOLT (HCF)**

The Hollo-Bolt is available in two versions: the original 3-part design for general hollow section connections and the larger sized 5-part **High Clamping Force (HCF)** version, for higher strength structural connections.

**3-PART HOLLO-BOLT**

M8 M10 M12

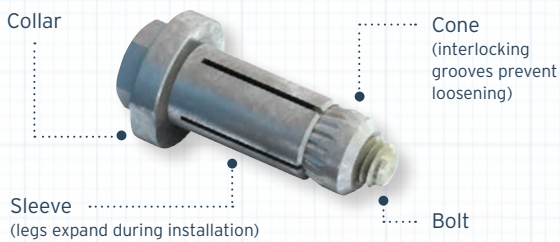

→ ← = Clamping Force

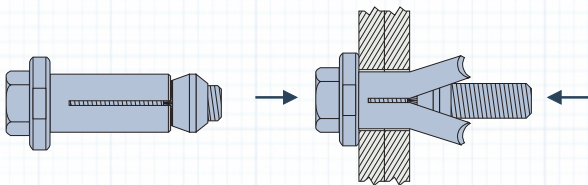

A typical connection is made by inserting the Hollo-Bolt into the pre-drilled holes of the fixture and hollow section. As the bolt head is tightened, the cone is pulled up the bolt thread, causing the legs of the sleeve to expand until the cone locks the sleeve against the inner wall of the hollow section.

At full tightening torque, a clamping action is set up between the fixture and the steel section to form a secure connection. Once installed, only the head and collar are visible.

**5-PART HOLLO-BOLT (HCF)**

**HIGH CLAMPING FORCE**

M16 M20

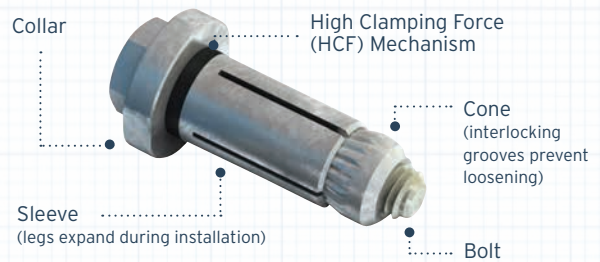

→ ← = Clamping Force

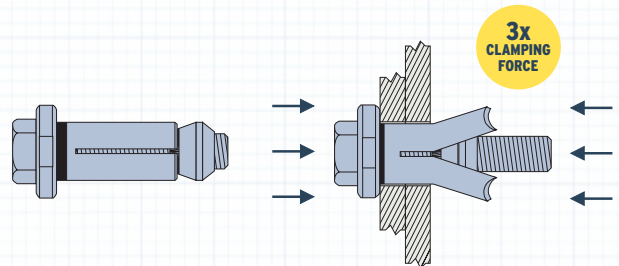

Working closely with Structural Engineers and Steel Fabricators, Lindapter identified the need for the larger M16 and M20 Hollo-Bolts to have an increased clamping force suitable for higher strength structural connections. Research and Development led to the invention of the patented 5-part design, optimised for superior performance.

The High Clamping Force (HCF) mechanism consists of a special washer that 'compresses' to significantly increase clamping force between the fixture and hollow section, when compared to a 3-part product of the same size, thereby reducing displacement.

**HOLLO-BOLT (HCF)  
TYPICAL PERFORMANCE INCREASE**

■	<b>With HCF Mechanism</b> 5-Part Design ▶ Hot Dip Galvanised, Size 2	■	<b>Without HCF Mechanism</b> 3-Part Design ▶ Hot Dip Galvanised, Size 2
---	--	---	---

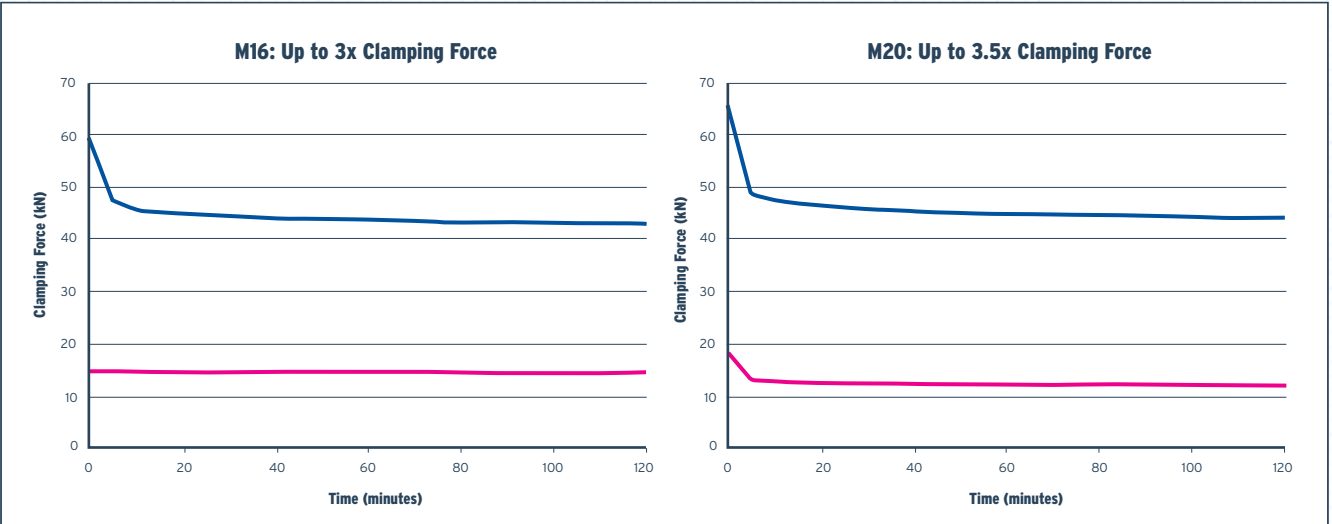

**CLAMPING FORCE**

As with any structural bolt, immediately after installation the bolt relaxes until a typical clamping force is reached. The typical clamping force of the Hollo-Bolt (HCF) is over three times higher than the same sized product without the HCF mechanism. This results in a more secure connection and a greater force that has to be overcome before displacement begins.

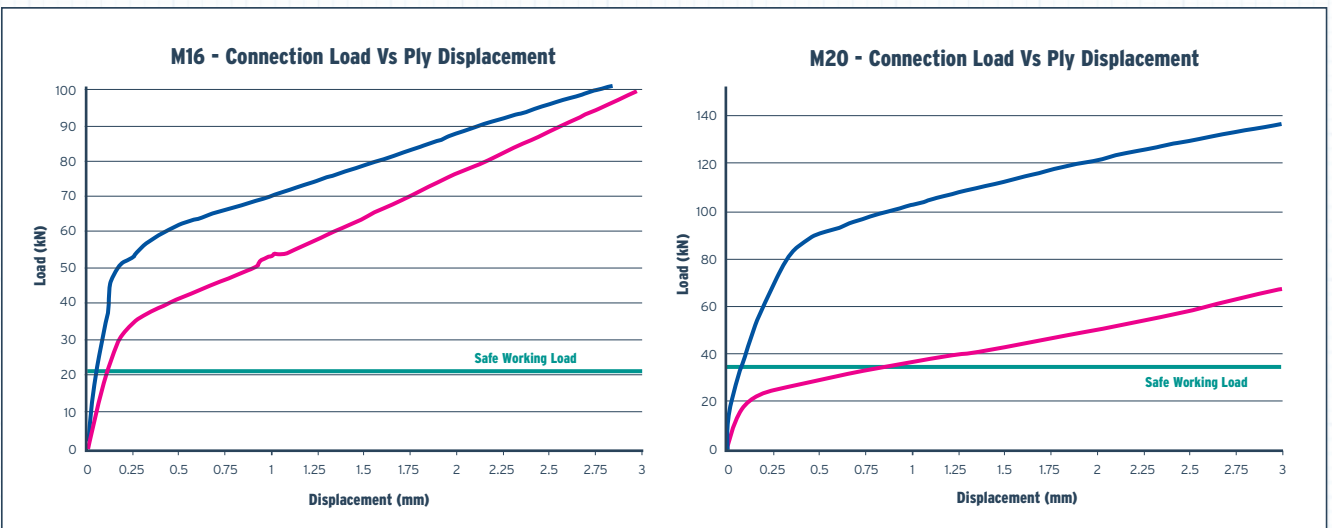

**DISPLACEMENT**

The significance of increased clamping force is shown in the graphs above. The blue curve demonstrates the superior performance of the Hollo-Bolt (HCF) in contrast to M16 & M20 sized products without Lindapter's patented HCF mechanism (i.e. the 3-part design in these larger sizes). When using the Hollo-Bolt (HCF), displacement (movement in the connection) is minimised at Safe Working Load for a safer and more secure connection.



SOCIÉTÉ GÉNÉRALE TRADING OFFICE



**APPLICATION**

Attaching façade glazing to the building's structural steel frame

**LOCATION**

Paris, France



**HEAD TYPE**

Hexagonal

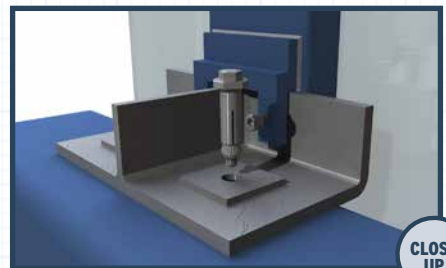
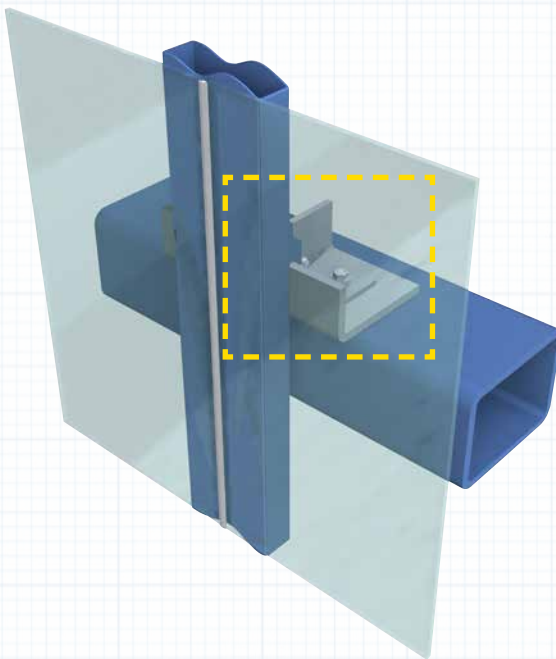

CLOSE UP



MANCHESTER MAGISTRATES COURT



**APPLICATION**

Connecting façade spider brackets to structural hollow section

**LOCATION**

Manchester, UK



**HEAD TYPE**

Hexagonal

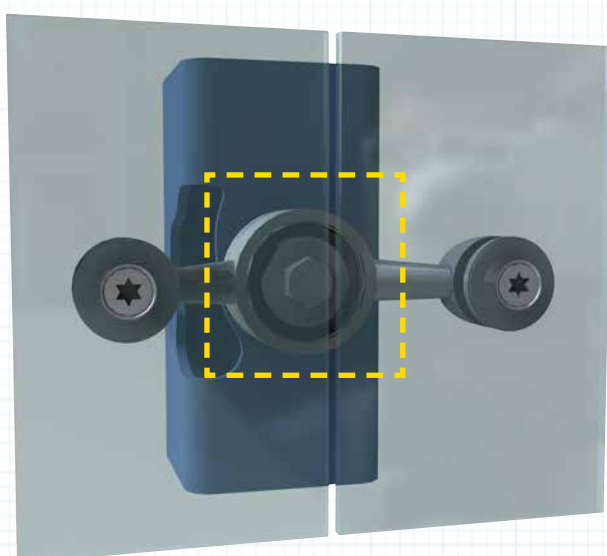

CLOSE UP



HISTORY MUSEUM



**APPLICATION**

Connecting perforated steel cladding to structural hollow section

**LOCATION**

Dresden, Germany



**HEAD TYPE**

Hexagonal

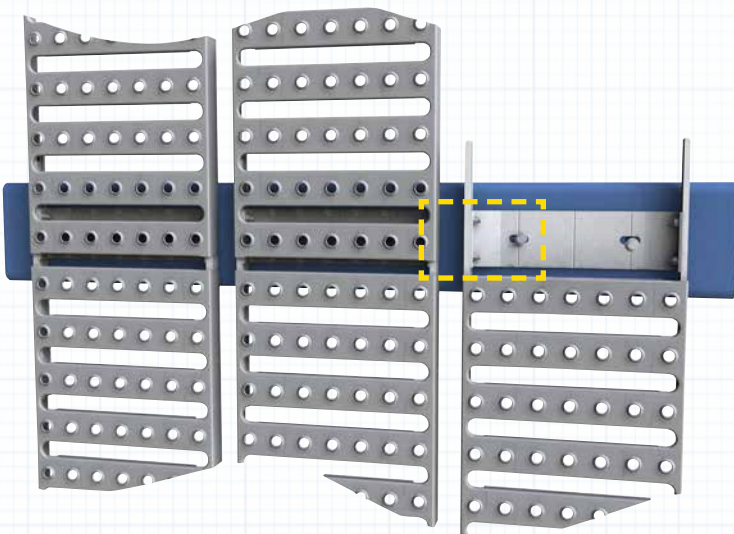

CLOSE UP



THAMES EXCHANGE

Image courtesy of OAG UK



**APPLICATION**

Structural connections of the elevator glazing frame

**LOCATION**

London, UK



**HEAD TYPE**

Countersunk  
(Bolt Head)

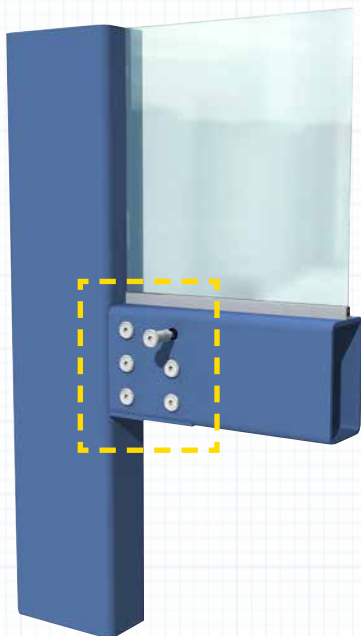

CLOSE UP



ROSE HILL CONSERVATORY



Image: The Huntington Library, Art Collections and Botanical Gardens

**APPLICATION**

Structural steel truss connections of the conservatory frame

**LOCATION**

San Marino, CA, USA



**HEAD TYPE**

Hexagonal

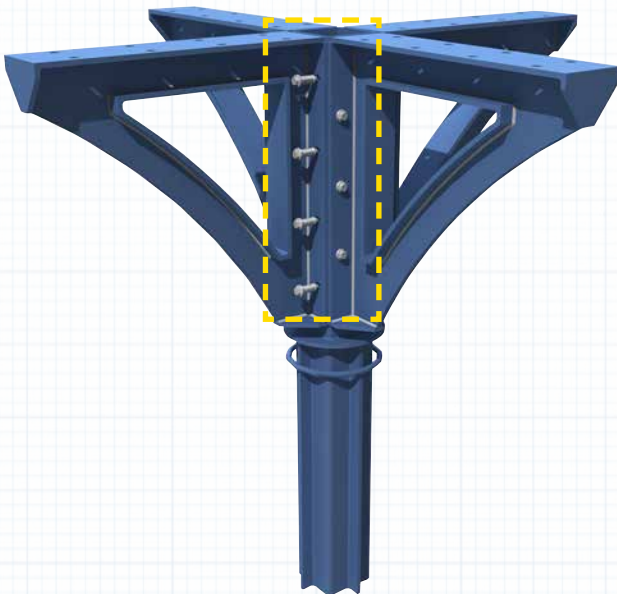

Image: Far Out Flora (faroutflora.com)



CLOSE UP



[www.hollo-bolt.com](http://www.hollo-bolt.com)



HAFEN CITY

Image: Quantum Immobilien AG



**APPLICATION**

Connecting the glazing support frame and roof

**LOCATION**

Hamburg, Germany



**HEAD TYPE**

Flush Fit

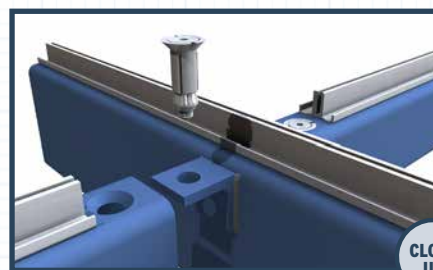
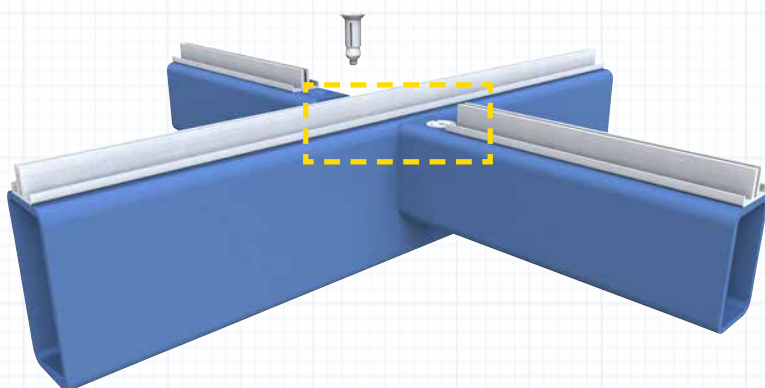

CLOSE UP



KIMMEL CENTER



Image: Jeff Goldberg/Esto, courtesy of Kimmel Center

**APPLICATION**

Connecting the barrel-vault roof

**LOCATION**

Philadelphia, PA,  
USA



**HEAD TYPE**

Hexagonal

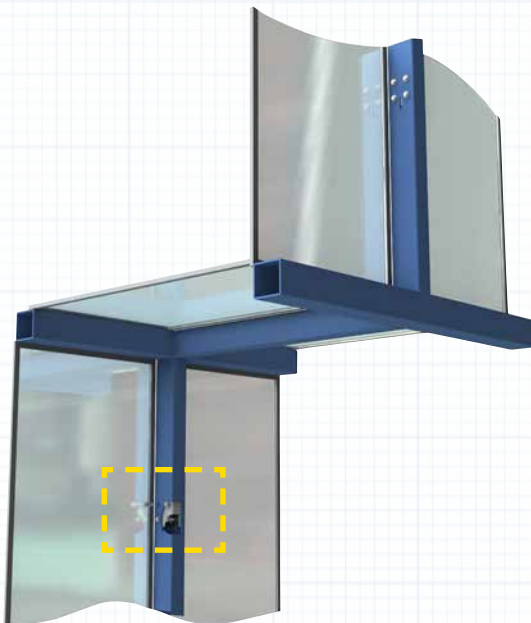
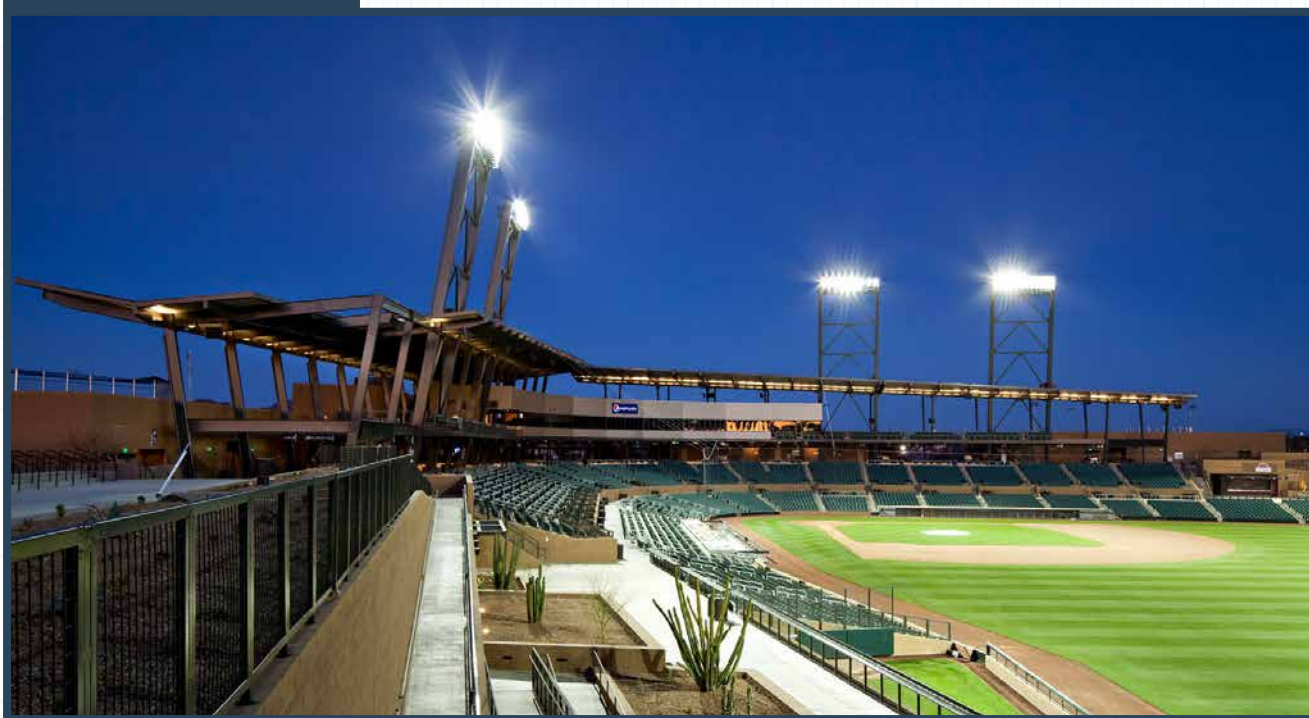

Image: R. Bradley Maule





SALT RIVER FIELDS STADIUM



**APPLICATION**

SHS connections for the floodlighting frame

**LOCATION**

Scottsdale, AZ,  
USA



**HEAD TYPE**

Hexagonal

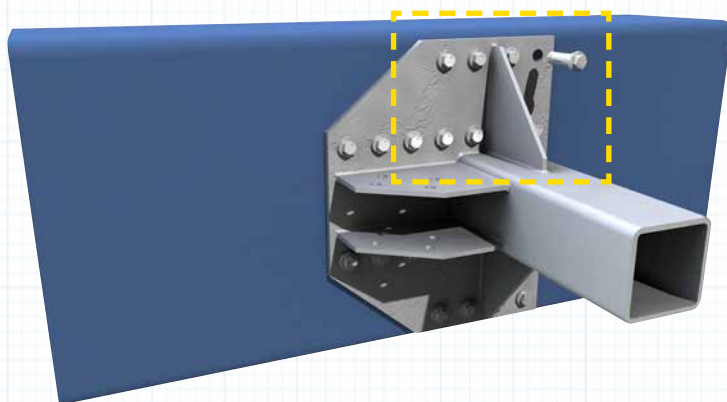

CLOSE UP



BMW WORLD



**APPLICATION**

Connection of mounting points for solar panels

**LOCATION**

Munich, Germany

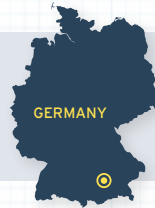

**HEAD TYPE**

Hexagonal

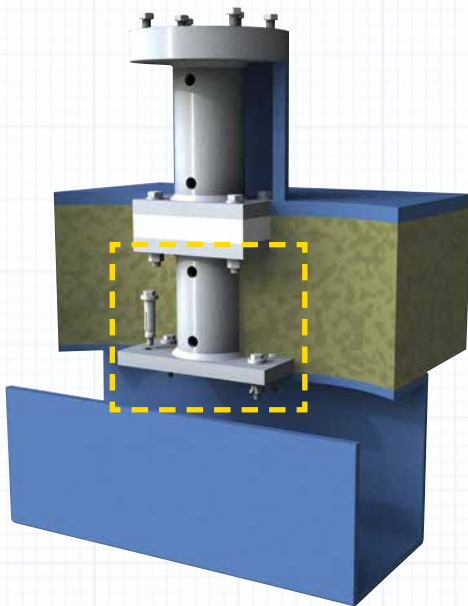

CLOSE UP



SNORRE OFFSHORE



**APPLICATION**

Securing handrails to fabricated hollow section

**LOCATION**

Norwegian  
North Sea



**HEAD TYPE**

Hexagonal

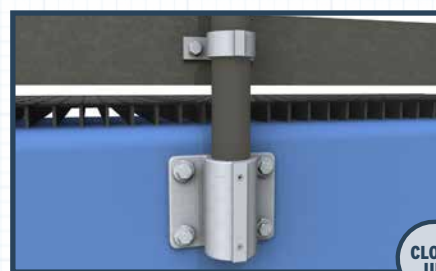
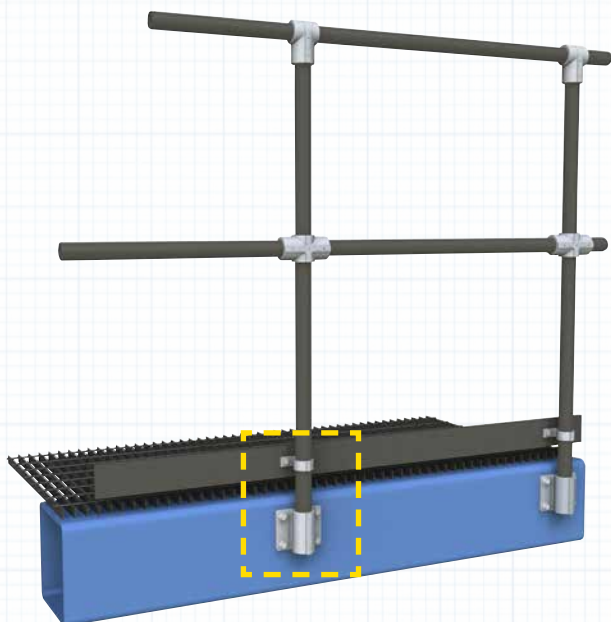

CLOSE UP



PHOENIX METRO LIGHT RAIL



**APPLICATION**

Securing station signage and seating to structural frames

**LOCATION**

Phoenix, AZ, USA



**HEAD TYPE**

Button Security



CLOSE UP



TELSTRA STADIUM / OLYMPIC STADIUM

Image: Brian Parcy



**APPLICATION**

Securing temporary seating to supporting steel structure

**LOCATION**

Sydney, Australia



**HEAD TYPE**

Hexagonal & Countersunk

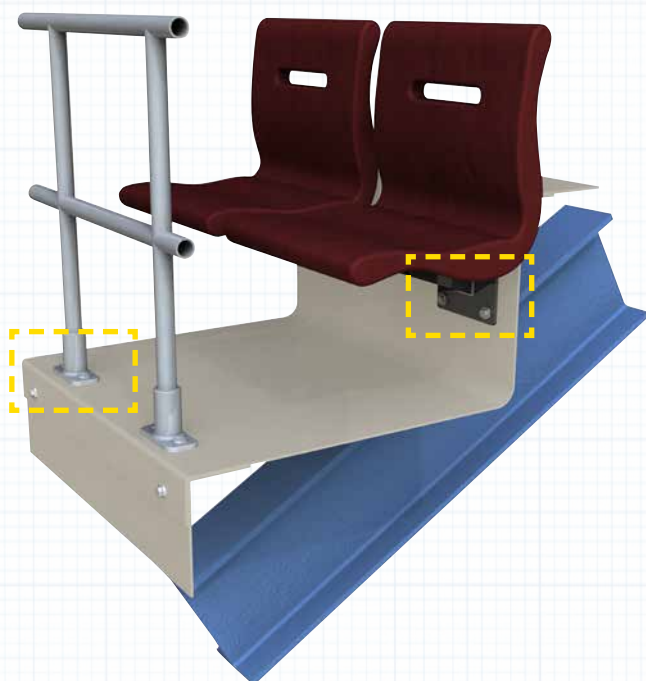

CLOSE UP



HEXAGONAL & COUNTERSUNK (BOLT HEAD)

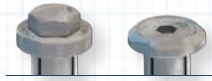

DRILLING & PREPARATION

Ensure that holes are drilled in both the fixture and the section according to the drilling guidance below.

Please note that clearance holes are slightly larger than standard bolt clearance holes to accommodate the sleeve and cone.

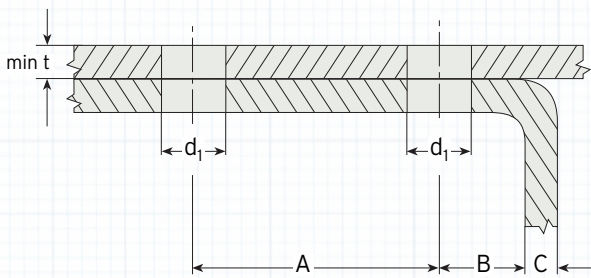

Size	Clearance Hole Ø $d_1$ mm	Hole Distances		Edge Distances B+C mm
		min A mm	min B mm	
M8	14 (+1.0 / -0.2)	35	13	B + C > 17.5
M10	18 (+1.0 / -0.2)	40	15	B + C > 22.5
M12	20 (+1.0 / -0.2)	50	18	B + C > 25.0
M16	26 (+2.0 / -0.2)	55	20	B + C > 32.5
M20*	33 (+2.0 / -0.2)	70	25	B + C > 33.0

\* Hexagonal Head only

➤ Sizes M16 and M20 require the thickness of the outer ply (min t) to be at least 8mm. If necessary, spacer washers should be used beneath the collar to increase the thickness to 8mm.

INSTALLATION

1 Align pre-drilled fixture and section and insert Hollo-Bolt<sup>a)</sup>.

2 Grip the Hollo-Bolt collar with an open ended spanner.

3 Using a calibrated torque wrench, tighten the central bolt to the recommended torque<sup>b)</sup>.

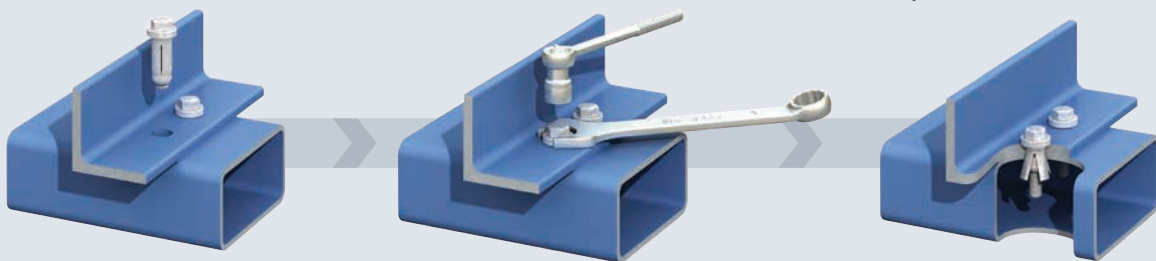

➤ a) Before tightening, ensure that the materials that are to be connected together are touching.

b) See page 22 for tightening torque.

Power tools, such as an impact wrench, may be used to speed up the tightening of the Hollo-Bolt. However, when using power tools, always complete the tightening process with a torque wrench to ensure the correct torque is applied to the Hollo-Bolt.



FLUSH FIT



DRILLING & PREPARATION

Ensure that countersunk holes are drilled in the fixture, and standard holes are drilled in the section, according to the drilling guidance below. Please note that clearance holes are slightly larger than standard bolt clearance holes to accommodate the sleeve and cone.

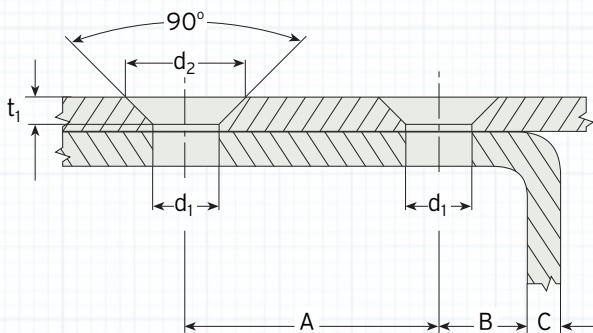

Size	Clearance Hole $\varnothing$ $d_1$ mm	Countersunk $\varnothing$ Depth		Hole Distances		Edge Distances B+C mm
		$d_2$ mm	$t_1$ mm	min A mm	min B mm	
M8	14 (+1.0 / -0.2)	27	6.5	35	13	B + C > 17.5
M10	18 (+1.0 / -0.2)	31	6.5	40	15	B + C > 22.5
M12	20 (+1.0 / -0.2)	35	7.5	50	18	B + C > 25.0

INSTALLATION

1 Align pre-drilled fixture and section and insert Hollo-Bolt<sup>a)</sup>.



2 Apply installation nut and grip with an open ended spanner.

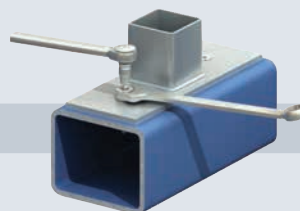

3 Using a calibrated torque wrench, tighten the central countersunk bolt to the recommended torque<sup>b)</sup>.

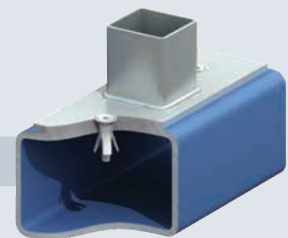

- a) Before tightening, ensure that the materials that are to be connected together are touching.
- b) See page 22 for tightening torque.

Power tools, such as an impact wrench, may be used to speed up the tightening of the Hollo-Bolt. However, when using power tools, always complete the tightening process with a torque wrench to ensure the correct torque is applied to the Hollo-Bolt.



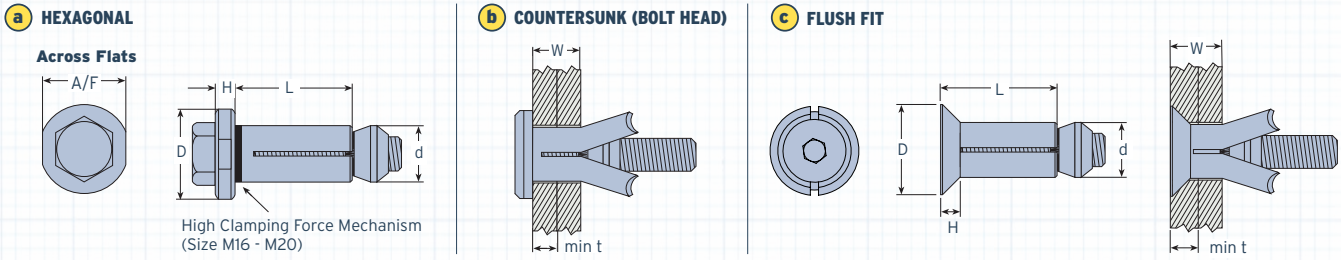

a HEXAGONAL		b COUNTERSUNK		Clamping Thickness W mm	Outer Ply <sup>1)</sup> min t mm	Sleeve		Collar			Tightening Torque Nm	Safe Working Loads <sup>2)</sup> (5:1 Factor of Safety)		
Product Code	Bolt mm	Product Code	Countersunk Bolt mm			Length L mm	Outer ø d mm	Height H mm	Ø D mm	A/F mm		Tensile kN	Single Shear kN	
HB08-1	M8 x 50	HBCSK08-1	M8 x 50	3 - 22	-	30					23	4.0	5.0	
HB08-2	M8 x 70	HBCSK08-2	M8 x 70	22 - 41	-	49	13.75	5	22	19	23	4.0	5.0	
HB08-3	M8 x 90	HBCSK08-3	M8 x 90	41 - 60	-	68								
HB10-1	M10 x 55	HBCSK10-1	M10 x 50	3 - 22	-	30								
HB10-2	M10 x 70	HBCSK10-2	M10 x 70	22 - 41	-	48	17.75	6	29	24	45	8.5	10.0	
HB10-3	M10 x 90	HBCSK10-3	M10 x 90	41 - 60	-	67								
HB12-1	M12 x 60	HBCSK12-1	M12 x 55	3 - 25	-	35								
HB12-2	M12 x 80	HBCSK12-2	M12 x 80	25 - 47	-	57	19.75	7	32	30	80	10.5	15.0	
HB12-3	M12 x 100	HBCSK12-3	M12 x 100	47 - 69	-	79								
High Clamping Force (HCF)	HB16-1	M16 x 75	HBCSK16-1	M16 x 70	12 - 29	8	41.5							
	HB16-2	M16 x 100	HBCSK16-2	M16 x 100	29 - 50	8	63	25.75	8	38	36	190	21.0	30.0
	HB16-3	M16 x 120	HBCSK16-3	M16 x 120	50 - 71	8	84							
	HB20-1	M20 x 90	-	-	12 - 34	8	50							
	HB20-2	M20 x 120	-	-	34 - 60	8	76	32.75	10	51	46	300	35.0	40.0
	HB20-3	M20 x 150	-	-	60 - 86	8	102							

➤ Sizes M16 and M20, known as the Hollo-Bolt (HCF), feature a patented **High Clamping Force** mechanism to produce three times more clamping force than the same sized product without the mechanism. The significance of clamping force and the superior performance of Lindapter's unique Hollo-Bolt (HCF) is illustrated on page 6.

c FLUSH FIT		Clamping Thickness W mm	Outer Ply min t mm	Sleeve		Collar		Installation Nut A/F mm	Tightening Torque Nm	Safe Working Loads <sup>2)</sup> (5:1 Factor of Safety)	
Product Code	Countersunk Bolt mm			Length L mm	Outer ø d mm	Height H mm	Ø D mm			Tensile kN	Single Shear kN
HBFF08-1	M8 x 50	10 - 27	8	35							
HBFF08-2	M8 x 70	27 - 45	8	54	13.75	5	24	19	23	4.0	5.0
HBFF08-3	M8 x 90	45 - 64	8	73							
HBFF10-1	M10 x 50	12 - 27	10	36							
HBFF10-2	M10 x 70	27 - 45	10	54	17.75	6	30	24	45	8.5	10.0
HBFF10-3	M10 x 90	45 - 64	10	73							
HBFF12-1	M12 x 55	12 - 30	10	42							
HBFF12-2	M12 x 80	30 - 52	10	64	19.75	7	33	30	80	10.5	15.0
HBFF12-3	M12 x 100	52 - 74	10	86							

1) Sizes M16 and M20 require the thickness of the outer ply (min t) to be at least 8mm. If necessary, spacer washers should be used beneath the collar to increase the thickness to 8mm.

2) The Hollo-Bolt can be used on a wide variety of steel hollow sections; safe working loads shown are based on use in S275 structural hollow section. The safe working loads, in both tension and shear, are applicable to the Hollo-Bolt only. Failure of the section, particularly on those with thin walls and a wide chord face, could occur at a lower figure and strength of the section should be checked by a qualified structural engineer.

The tables above state the safe working loads with a 5:1 factor of safety and should be used for secondary applications. For primary design, please consult the guide *Joints in Steel Construction - Simple Connections*. The guide provides design guidance for the use of Hollo-Bolt and gives essential information for structural steelwork connections for use in buildings designed by the 'Simple Method' i.e. braced frames where connections carry mainly shear and axial loads only. To obtain further details on the Simple Connections guide please contact:

**The Steel Construction Institute Tel: +44 (0) 1344 636 525 / Fax: +44 (0) 1344 636 570 / www.steel-sci.com**

Published by SCI/BCSA Connections Group. Publication Number: P212 / ISBN 1 85942 072 9.



www.hollo-bolt.com



Characteristic values of tensile and shear resistance for Holo-Bolt taken from ETA-10/0416. **For more information visit [www.lindapter.com/about/ce](http://www.lindapter.com/about/ce)**



### HOLLO-BOLT HEXAGONAL

Product Code	Nominal Size	Tensile $F_{t,Rk}$ (kN)	Shear $F_{v,Rk}$ (kN)	Material Strength of Sleeve (N/mm <sup>2</sup> )
HB08	M8	23.1	32.9	430
HB10	M10	39.6	54.2	430
HB12	M12	45.8	71.0	430
HCF HB16	M16	84.3	139.0	430
HCF HB20	M20	124.0	211.0	390

### HOLLO-BOLT HEXAGONAL STAINLESS STEEL

Product Code	Nominal Size	Tensile $F_{t,Rk}$ (kN)	Shear $F_{v,Rk}$ (kN)	Material Strength of Sleeve (N/mm <sup>2</sup> )
HBST08	M8	26.8	30.7	500
HBST10	M10	46.0	51.0	500
HBST12	M12	53.3	65.0	500
HCF HBST16	M16	98.0	128.0	500
HCF HBST20	M20	154.0	205.0	500

### HOLLO-BOLT COUNTERSUNK (BOLT HEAD)

Product Code	Nominal Size	Tensile $F_{t,Rk}$ (kN)	Shear $F_{v,Rk}$ (kN)	Material Strength of Sleeve (N/mm <sup>2</sup> )
HBCSK08	M8	23.1	32.9	430
HBCSK10	M10	39.6	54.2	430
HBCSK12	M12	45.8	71.0	430
HCF HBCSK16	M16	84.3	139.0	430

### HOLLO-BOLT COUNTERSUNK (BOLT HEAD) STAINLESS STEEL

Product Code	Nominal Size	Tensile $F_{t,Rk}$ (kN)	Shear $F_{v,Rk}$ (kN)	Material Strength of Sleeve (N/mm <sup>2</sup> )
HBSTCSK08	M8	26.8	30.7	500
HBSTCSK10	M10	46.0	51.0	500
HBSTCSK12	M12	53.3	65.0	500
HCF HBSTCSK16	M16	98.0	128.0	500

➤ Sizes M16 and M20, known as the Holo-Bolt (HCF), feature a patented **High Clamping Force** mechanism to produce three times more clamping force than the same sized product without the mechanism. The significance of clamping force and the superior performance of Lindapter's unique Holo-Bolt (HCF) is illustrated on page 6.

### HOLLO-BOLT FLUSH FIT

Product Code	Nominal Size	Tensile $F_{t,Rk}$ (kN)	Shear $F_{v,Rk}$ (kN)	Material Strength of Sleeve (N/mm <sup>2</sup> )
HBFF08	M8	23.1	32.9	430
HBFF10	M10	39.6	54.2	430
HBFF12	M12	45.8	71.0	430

### HOLLO-BOLT FLUSH FIT STAINLESS STEEL

Product Code	Nominal Size	Tensile $F_{t,Rk}$ (kN)	Shear $F_{v,Rk}$ (kN)	Material Strength of Sleeve (N/mm <sup>2</sup> )
HBSTFF08	M8	26.8	30.7	500
HBSTFF10	M10	46.0	51.0	500
HBSTFF12	M12	53.3	65.0	500

### HOLLO-BOLT BUTTON HEAD / SECURITY

\* Please contact Lindapter to discuss the available options.

Product Code	Nominal Size	Tensile $F_{t,Rk}$ (kN)	Shear $F_{v,Rk}$ (kN)	Material Strength of Sleeve (N/mm <sup>2</sup> )
HBBH/HBFT/HBPR	M8	23.1	32.9	430
HBBH/HBFT/HBPR	M10	39.6	54.2	430
HBBH/HBFT/HBPR	M12	45.8	71.0	430

➤ **The characteristic values for the Holo-Bolt listed in the above tables are for use when designing bolted connections to Eurocode 3 only, these are not standard safe working loads.**

Holo-Bolt lengths 1, 2 and 3 are covered by this ETA 10/0416. The characteristic values are used to determine the design resistance of the Holo-Bolt. The design resistance is calculated by dividing the characteristic value by a partial factor  $\gamma_{m2}$ . The partial factor is a nationally determined parameter (for example:  $\gamma_{m2}=1.25$  in the UK). For Holo-Bolt safe working loads with a factor of safety of 5:1 please refer to the Holo-Bolt tables on Page 22 of this brochure.

The characteristic values are valid for the Holo-Bolt assembly itself, in any connection detail the design resistance of the connection may be limited to a lesser value. For example, when the thickness of the connected component is small, pull out failure may occur before failure of the Holo-Bolt.

Design checks should be carried out on the section member to determine the static design resistance. The SCI Greenbook publication P.358 Joints in Steel construction, Simple Joints to Eurocode 3 contains a number of checks on the section. The characteristic values are only valid when the Holo-Bolts are installed as per our installation instructions.

The SCI Greenbook publication P.358 Joints in Steel construction, Simple Joints to Eurocode 3 contains a number of checks on the section. The characteristic values are only valid when the Holo-Bolts are installed as per our installation instructions. To obtain further details on the Simple Connections guide please contact:

The Steel Construction Institute Tel: +44 (0) 1344 636 525 / Fax: +44 (0) 1344 636 570 / [www.steel-sci.com](http://www.steel-sci.com)

Published by SCI/BCSA Connections Group. Publication Number: P358 / ISBN 978-1-85942-201-4.







## YOUR QUESTIONS ANSWERED...

**Can Lindapter Holo-Bolts be used in all sizes & shapes of SHS?**

Yes, the Lindapter Holo-Bolt can be used in all sizes of Structural Hollow Section (SHS) and is suitable for use in those of square, rectangular, circular or elliptical shape.

**The capacity figures for the Lindapter Holo-Bolts shown in both SCI 'Green Books' are different to the figures shown in the Lindapter catalogue. Which figures should I use?**

The loads shown on page 22 of this brochure are Safe Working Loads, with Lindapter's typical Factor of Safety of 5:1, and are for general use.

For structural use, the loads shown in the SCI design guides are not Safe Working Loads, they are Design Capacities, to be compared in calculations with the structural capacity of the supporting column wall (SHS).

**Who is responsible for checking the capacity of the structural section when using Lindapter Holo-Bolts?**

It is the responsibility of a Structural Engineer to ensure a hollow section has sufficient capacity to take the necessary loads. Help can be found within either of the current SCI/BCSA 'Green Books', where P.212 should be used if designing simple connections to BS5950 whilst P.358 should be used if designing simple joints to Eurocode 3.

**How does the HCF mechanism increase clamping force?**

Without the HCF mechanism on the larger sizes (M16 & M20), the majority of the preload in the bolt is transferred into expanding the sleeve. Lindapter's patented HCF mechanism in the 5-part Holo-Bolt (HCF) allows the sleeve to expand and converts some of the preload into clamping force to hold the connection securely together.

**What is the significance of increased clamping force?**

Clamping force is the compressive force which holds the connection together. An M16 or M20 connection using the 5-part Holo-Bolt (HCF) will be held together with a greater force than a 3-part product of the same size, and have less movement at safe working load. With the 5-part Holo-Bolt (HCF), a higher load is needed initially to pull the connection apart.

**Why don't you make all Holo-Bolts to the 5-part design?**

The M16 & M20 sized Holo-Bolt (HCF) was designed specifically for larger structural connections that require high clamping force. The Holo-Bolt M8, M10 & M12 are not generally used for structural joints and adding the HCF mechanism to these smaller sizes would not create a significant advantage when compared to the superior performance of the M16 and M20 Holo-Bolt (HCF).

**Why is there some displacement, even on the Holo-Bolt (HCF)?**

The Holo-Bolt is a ductile connection and the chord face of the hollow section can deflect. The Safe Working Load for the Holo-Bolt has been set at an area of minimal displacement (please view the Load/Displacement graphs on page 7).



**Can Hollo-Bolts be used in slotted holes?**

Yes, it is possible to use Hollo-Bolts with slotted holes in the outer bracket or end plate as long as there is no horizontal load in the direction of the slot. However, the hole in the hollow section into which the Hollo-Bolt is to be installed must be circular and within the tolerance stated in this brochure.

**Can Lindapter Hollo-Bolts be sealed to prevent water ingress?**

Yes. Although the vast majority of Lindapter Hollo-Bolts used globally do not use any sealing method, special washers have been supplied on a limited number of occasions. However, it is important not to ignore the interface between the structural tube and plate or bracket which is being attached.

**Can I use stainless steel Hollo-Bolts to connect brackets to mild steel hollow section?**

Where possible the best option is to ensure that the section, bracket and Hollo-Bolt are all produced from the same material, or are close to each other on the galvanic corrosion chart. If stainless components are in contact with mild steel, bimetallic corrosion will be accelerated.

**Can I use Hollo-Bolts in concrete filled sections?**

The Hollo-Bolt was designed for connecting to structural sections and needs an obstacle free area for the sleeve to expand. Once the component is installed correctly the section can then be filled with concrete.

**@ IF YOU HAVE ANY FURTHER QUESTIONS  
PLEASE CONTACT [enquiries@lindapter.com](mailto:enquiries@lindapter.com)**

**Are Lindapter Hollo-Bolts removable?**

Yes. Although designed as a permanent connection, it is possible to remove the Hexagon and Countersunk (Bolt Head) variants by following this procedure:

1. Grip the Hollo-Bolt collar with an open ended spanner / wrench to prevent the collar from rotating.
2. Use an impact wrench / torque wrench to remove the bolt (anti-clockwise rotation).
3. Hollo-Bolt sizes M8, M10 & M12 only: remove the sleeve by prying the collar with a pinch or crow bar. Note: this additional step is not required to remove the M16 & M20 due to their 5-part design.

The special Security Button Head Hollo-Bolt is designed so that it cannot be easily removed without the Security Key.

**Can I use the Hollo-Bolt to connect timber to steel?**

Yes, although it is important to ensure that the timber is capable of withstanding the clamping force created when applying torque to the Hollo-Bolt. In some cases a spreader washer can be used under the collar of the Hollo-Bolt to distribute the force over a greater area.

**Why aren't all the head variants available in Hot Dip Galvanised finish?**

When components with a hexagon socket are Hot Dip Galvanised, the high build up of zinc in the recess results in a reduced A/F dimension meaning that a standard Allen/Hexagon Key no longer fits correctly. This would make it very difficult for the installer to apply the required torque to ensure the Hollo-Bolt expands correctly.



**TECHNICAL SUPPORT**

The comprehensive technical support from Lindapter's experienced engineers ensures an efficient specification process with a free connection design service and bills of materials upon request. Lindapter's philosophy is to deliver the highest quality at every stage of the service, from initial connection design to installation guidance.

- Free connection design based on your requirement
- Optimised solution for cost and performance
- Bespoke drawings delivered in 2D and interactive 3D formats
- CAD files for import into major software applications
- Contractor training

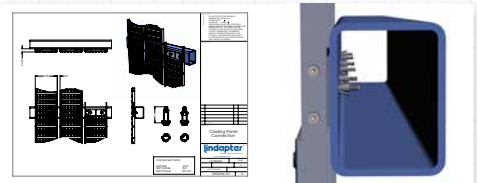

**ENGINEERED SOLUTIONS**

Lindapter's unique R&D capability facilitates a bespoke product development service, passionately referred to as 'Engineered Solutions'.

The service offered to clients includes:

- Design and development of customised products
- Full strength and performance analysis
- Thoroughly tested with detailed reports
- Manufactured to Lindapter's exacting standards

**R&D Facility** >  
One of two  
1000 kN  
testing machines

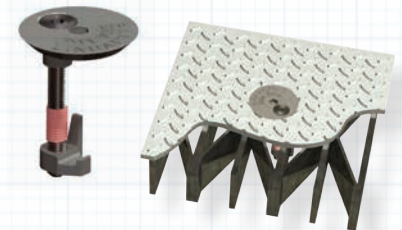

**^ Type 1055**  
Bespoke product designed to fit solid plate flooring to open grid flooring for Amec/Shell

**LINDIBOLT® 2**



In addition to the Hollo-Bolt, Lindapter also invented the Lindibolt. The self heading expansion bolt is suitable for connecting steelwork to hollow-sections, tubes and where access is available from one side only. The Lindibolt 2 uses a standard clearance hole for convenience.

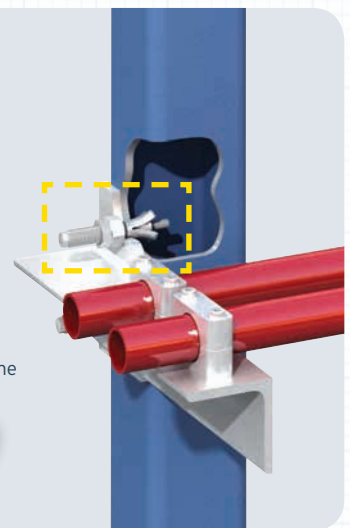
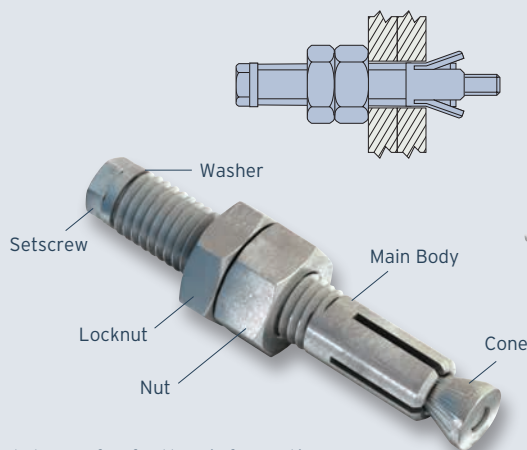

➤ Please refer to the full Lindapter catalogue for further information.



FULL PRODUCT RANGE

# LINDAPTER CATALOGUE

## WHAT'S INSIDE?



### STEELWORK FIXINGS

Lindapter has pioneered a unique & proven concept: innovative clamping systems that eliminate the need to weld or drill, reducing installation time & labour costs.



### CAVITY FIXINGS

The range consists of the legendary Hollo-Bolt and Lindibolt, creating simple, cost-effective connections for SHS and other hollow sections.



### COMPOSITE DECKING FIXINGS

Easy to install connections to fit inside the dovetail shaped re-entrant channel of all major decking profiles. Ideal for supporting HVAC equipment and cable trays without weakening the decking profile.



### SUPPORT FIXINGS

Lindapter provides a wide range of connection solutions for suspending building services, such as pipe work, sprinklers & suspended ceilings, from structural or supporting steel.



### FLOOR FIXINGS

Lindapter's unique no-weld no-drill concept extends to the connection of steel flooring. Open bar grating & chequer plate flooring can be installed by one person from above.

**AVAILABLE NOW!**

**Technical Innovation in Steelwork Connections**

Established 1934

**Type AF Steelwork Fixings**

Typical applications: Vertical connections, Horizontal connections, Suspended ceiling, Floor Fixings

**Type AF** (with top flange)  
**Type AF & AFH** (without top flange)  
**Type AF & AFH** (without top flange, with top plate)

**Technical specifications:**

Product	Ref.	Height	Width	Weight	Max. load	Max. span	Max. deflection
AF10	100	100	100	0.5	100	100	100
AF15	150	150	150	0.7	150	150	150
AF20	200	200	200	1.0	200	200	200
AF25	250	250	250	1.3	250	250	250
AF30	300	300	300	1.7	300	300	300
AF35	350	350	350	2.1	350	350	350
AF40	400	400	400	2.6	400	400	400
AF45	450	450	450	3.1	450	450	450
AF50	500	500	500	3.7	500	500	500
AF55	550	550	550	4.3	550	550	550
AF60	600	600	600	5.0	600	600	600
AF65	650	650	650	5.7	650	650	650
AF70	700	700	700	6.5	700	700	700
AF75	750	750	750	7.3	750	750	750
AF80	800	800	800	8.2	800	800	800
AF85	850	850	850	9.1	850	850	850
AF90	900	900	900	10.1	900	900	900
AF95	950	950	950	11.1	950	950	950
AF100	1000	1000	1000	12.2	1000	1000	1000

© Lindapter 2023. All rights reserved. For more information, visit [www.lindapter.com](http://www.lindapter.com)

**Request your copy today by contacting [enquiries@lindapter.com](mailto:enquiries@lindapter.com)**



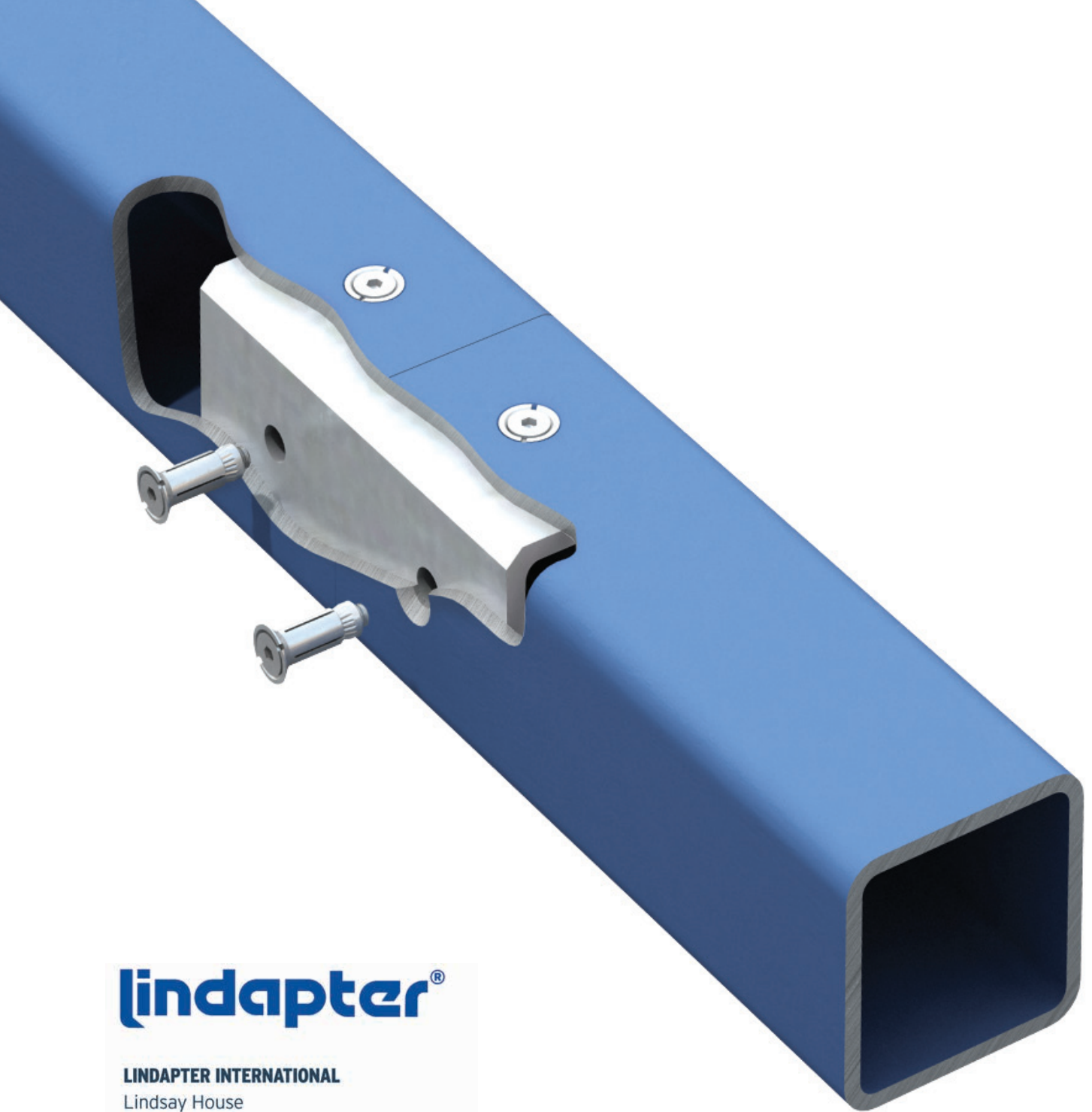

**lindapter®**

**LINDAPTER INTERNATIONAL**

Lindsay House  
Brackenbeck Road  
Bradford BD7 2NF  
England

T: +44 (0) 1274 521444

F: +44 (0) 1274 521130

E: [enquiries@lindapter.com](mailto:enquiries@lindapter.com)

[www.lindapter.com](http://www.lindapter.com)

---

Your Authorised Lindapter Distributor: